

EKF 511 TC - COMBI OVEN WITH TOUCH CONTROL
5 TRAYS/GRIDS 1/1 GN

EKA TOUCH LINE

COOKING

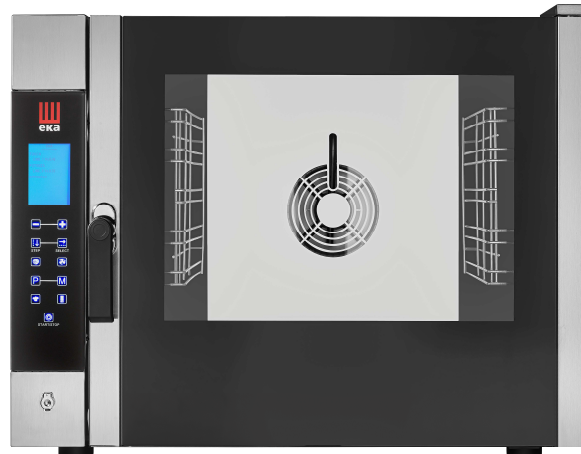

The smallest of the range Touch but not the least performer.

Designed for the most demanding professionals who need to combine the technology of a high performance product with the limited spaces of their kitchens. Lasagnas, pancakes, roasted fillets, vacuum cooking, side dishes steamed or au gratin: all this and much more thanks to the features of direct steam and possibility to store up to 240 recipes.

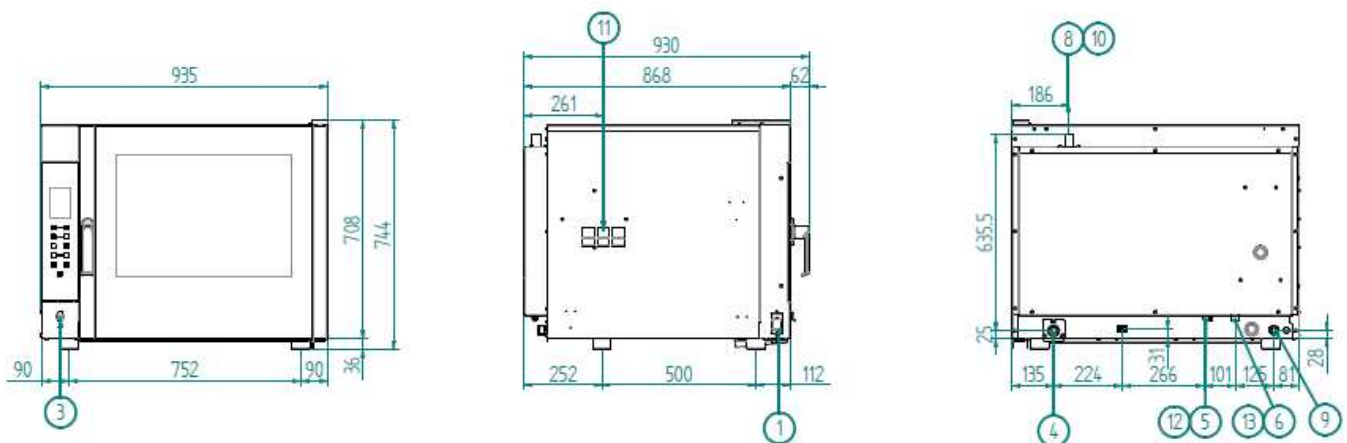

LEGEND

1	USB PORT	11	DON'T CLOG UP VENTILATION OPENINGS
2	SERIAL PORT	12	WATER INLET MAX. 200 kPa
3	PLUG FOR CORE PROBE	13	SOFTENED WATER INLET MAX 200 kPa
4	WATER OUTLET TUBE	14	BOILER CLEANING INLET
5	WASHING WATER INLET	15	DON'T OPEN CAP WHILE WORKING
6	SOFTENED WATER INLET	16	GAS INLET THREADED JOINT 3/4"
7	WATER INLET	17	POWER SUPPLY TO TOP OVEN
8	STEAM OUTLET	18	PRE-CARVED HOLE FOR BOTTOM OVEN POWER SUPPLY
9	ELECTRIC CABLE FIXER	19	STEAM SUCTION PIPE
10	CAUTION! HOT SURFACE		

DIMENSIONAL FEATURES				FUNCTIONAL FEATURES			
DIMENSIONS	W	D	H	POWER	ELECTRICITY		
OVEN DIMENSIONS (mm)	935	930	745	CAPACITY	N° 5 TRAYS/GRIDS 1/1 GN		
CARDBOARD BOX DIMENSIONS WITH PALLET (WxDxH mm)	1000	990	910	TYPE OF COOKING	VENTILATED		
OVEN DIMENSIONS (inches)	36,81	33,97	29,33	STEAM (see legend)	DIRECT STEAM CONTROLLED BY TOUCH SCREEN (10 LEVELS)		
CARDBOARD BOX DIMENSIONS WITH PALLET (inches)	39,37	38,97	35,82	COOKING CHAMBER	AISI 304 STAINLESS STEEL		
OVEN WEIGHT (kg)	84			WATER OUTLET	Ø 30mm TUBE		
PACKED OVEN WEIGHT (kg)	101,8			STEAM OUTLET	DIRECT		
OVEN WEIGHT (lbs)	185,18			TEMPERATURE	30 + 260°C		
PACKED OVEN WEIGHT (lbs)	224,43			TEMPERATURE CONTROL	DIGITAL PROBE THERMOMETER		
DISTANCE BETWEEN RACK RAILS (mm)	68			CONTROL PANEL	TOUCH CONTROL – LEFT SIDE		
FAN DIMENSION (mm)	Ø 198 - NR. 45 BLADES			N° OF PROGRAMS	240		
CENTER-TO-CENTER DISTANCE BETWEEN FEET (mm)	752			PROGRAMMABLE COOKING STEPS	9		
				PRE-HEATING TEMPERATURE	180°C		
ELECTRICAL FEATURES				PRE-HEATING FUNCTION	PROGRAMMABLE		
POWER SUPPLY (kW)	8,2			DOOR	RIGHT SIDE OPENING – ALL GLASS DOOR		
FREQUENCY (Hz)	50/60				VENTILATED		
VOLTAGE (Volt)	AC 380/400 3N				INSPECTIONABLE GLASS		
N° OF MOTORS	1 BIDIRECTIONAL			MODULARITY	AVAILABLE		
RPM	2800/1400/1100			FEET	NOT ADJUSTABLE		
				EQUIPMENT			
N° OF RESISTORS	CIRC.	1 pcs	8 kW	LATERAL SUPPORTS	1RIGHT + 1LEFT		
	TOP+GRILL	/	/	CABLE	THREE-PHASE [5G 2,5] - L=1250 mm		
	SOLE	/	/	MANUAL + AUTOMATIC WASHING SET UP			
BOILER	/			USB PORT			
LIMIT CONTROL	UNIPOLAR WITH MANUAL RESET			REMOVABLE DRIP BOX			
PROTECTION AGAINST WATER	IPX 5			PLUG FOR CORE PROBE			
LIGHTING	NR.1 LED BAR (IN THE DOOR)						
PLUS				OPTIONAL			
USB PORT TO UPLOAD AND DOWNLOAD RECIPES AND HACCP DATA	ADJUSTABLE DOOR HINGES			CHROMED GRID 1/1 GN	COD.KG9G	CORE PROBE	COD. EKSC
240 STORABLE RECIPES (40 EKA RECIPES, 200 USER-SETTABLE RECIPES)	QUICK FASTENING OF LATERAL SUPPORTS			AISI 304 VERTICAL CHICKEN COOKING PAN	COD.KGP	CORE PROBE WITH SUPPORT	COD. EKSCS
DELAYED START FUNCTION UP TO 23 HOURS AND 59 MINUTES	STAINLESS STEEL COOKING CHAMBER			AISI 304 TRAY 1/1 GN (530x325x40 mm)	COD. KT9G	SELF-CLEANING AUTOMATIC SYSTEM	COD. KWT
10 LANGUAGES FOR THE CONTROL PANEL (ITALIAN-FRENCH-ENGLISH-GERMAN-SPANISH-ROMANIAN-POLISH-BULGARIAN-UKRAINIAN-RUSSIAN)	EMBEDDED GASKET			TABLE	COD. EKT 711 – COD. EKTR 711 – COD. EKTS 711 – COD. EKTRS 711 – COD. EKT 711 D	SPRAY KIT WITH SUPPORT	COD. EKKD
CHAMBER DRAIN FOR LIQUIDS	STACKABLE			CONDENSATION HOOD	COD. EKKC6	SPARKLING AID	COD. KBRILD AND COD. KBRILMD
DIRECT CHIMNEY FOR COOKING FUMES/STEAM	FORCED COOLING SYSTEM OF INNER PARTS			AIR REDUCER	COD. EKRP A	CLEANING FLUID	COD. KDET
DOUBLE CONNECTION WATER ENTRY (NORMAL AND SOFTENED)	IPX 5						
"ALL GLASS" DOOR WITH "SATIN-FINISH" (AISI 304) STAINLESS STEEL SIDE PROFILES	MANUAL+AUTOMATIC WASHING SET UP						
QUICK COOLING OF COOKING CHAMBER	CB CERTIFICATION						
SCREEN-PRINTED GLASS CONTROL PANEL							

LEGEND
STEAM

A pipe sprays the water directly on moving fans. It's ideal for roast meat, fish and steamed vegetables.